

MIDLAND COUNTY ROAD COMMISSION

BID FORM

Sealed Proposals will be received at the office of the Board of County Road Commissioners, County of Midland, located at 2334 N. Meridian Road, Sanford, Michigan 48657 until

DATE: Wednesday, April 15th, 2015, at 2:00 p.m.

Item No. 15 – a. STEEL BEAM GUARDRAIL MATERIALS AND INSTALLATION
b. NU-GUARD-31 ROADSIDE BARRIER MATERIALS AND INSTALLATION

a.

DESCRIPTION

Table with 2 columns: Description and Unit. Items include Treated Wood Post (6'x8'x6', 6'x8'x7', 6'x8'x8'), Steel Guardrail Post (6', 7', 8'), Galvanized Beam Guardrail (Type B, Thrie Beam), SRT Guardrail Ending, ET 2000 Guardrail Ending, 6'3" Transitions with Beam to Thrie Beam, 12'6" Panels Thrie Beam, 12'6" Panels Type B Steel Beam Guardrail, 98" Buffered Ends, Fleat, SKT 350, ET, and Installation County Wide Per Lineal Ft.

b.

DESCRIPTION

Table with 2 columns: Description and Unit. Items include Nu-Guard, Rib-Bak (5 lb. x 6.5', 5 lb. x 8.5'), Nu-Guard, Washer (3.5" D), and Nu-Guard-31 system, Installed, Estimated 2500 lft.

All work shall be performed in a timely manner as determined by Midland County Road Commission. Locations of work shall vary across Midland County including on county roads and state highways. Contractor shall provide labor and materials for complete installation per the MDOT 2012 specification and MDOT Standard Plans. Bid items are listed as follows with estimated quantities as may be required.

Contractor shall submit detailed and itemized invoice within 30 days of work. Failure to provide invoice with 30 days shall result in forfeiture of reimbursement.

COMPANY _____

ADDRESS _____

PHONE/FAX _____

Authorized Signature Title
INDICATE ON ENVELOPE: Company Name, Item Number, Bid Item, Time and Date

Contact Information for Nu-Guard-31:

Nucor Steel Marion
Mark Fellows
740-341-9181

Trinity Highway
David Hynes
800-282-7668

Nu-Guard-31™

For the 31" configuration, the system utilizes the following components:

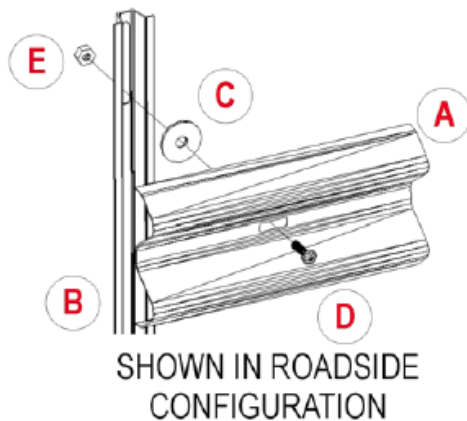

A: RAIL:

W-BEAM, AASHTO M-180, CLASS A or B,
GALVANIZED TYPE II

B: POST:

5 lb./ft. (7.45 kg/m) X 6'-6" Rib-Bak® U-
CHANNEL POST, GALVANIZED OR POWDER-
COATED, NUCOR GRADE SP-80

C: SPACER WASHER:

1/4" X 3 1/2" ROUND WASHER, GALVANIZED,
ASTM A307

D: BOLT:

FOR ROADSIDE: 5/8" X 3 1/2" BUTTON HEAD
POST BOLT, GALVANIZED, ASTM A307

FOR MEDIAN: 5/8" X 4" BUTTON HEAD POST
BOLT, GALVANIZED, ASTM A307

E: NUT:

5/8" DOUBLE RECESSED NUT, GALVANIZED,
ASTM A307

This system may also be installed in **double-faced (median)** configuration, as represented in the following image. In which case, **a second spacer washer per post is required**. When installing in median configuration, be sure to alternate the direction of the post bolts at each post connection point.



Connection At Beam Splice

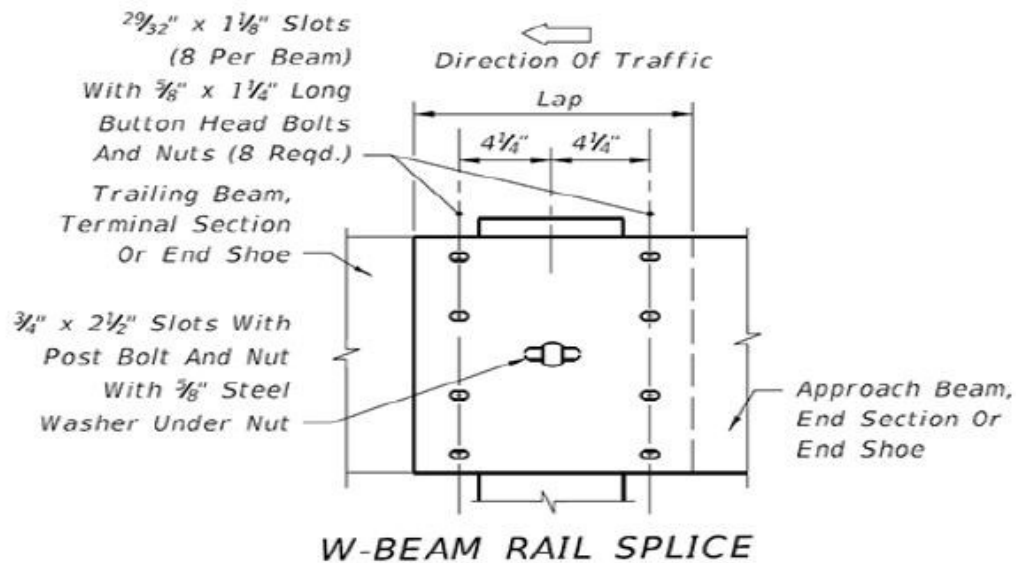

Typical Rail Splice connection detail. Source FLDOT 2014.

Shown is the standard overlap and splicing connection detail for w-beam guardrail systems. In some cases, some roadway authorities require the use **(1) additional washer under** on the post bolt at the backside of post. Be sure to check your local standards to meet compliance with hardware requirements.

Outlined below are the key steps that have been used by the manufacturer to easily install Nu-Guard-31™ median barriers once the posts have been driven:

- Splice the next guardrail panel to the existing guardrail end with 8 splice bolts and tighten.
- Insert a 24" steel rod half way through the post bolt slot of the guardrail panel and the vertical slot of the Nu-Guard-31™ post. (This will hold the panel at the correct height while the secondary panel is attached)
- Lever the existing secondary guardrail panel out laterally from the post to gain access. (This is easily achieved because this existing guardrail panel also has a 24" steel rod through the center post bolt slot at this stage and is only connected to the post and guardrail panel at the far end)
- Connect the next secondary guardrail panel to the exposed end with 8 splice bolts and tighten.
- Release the levered secondary guardrail panel so that it returns to the required position against the posts and the 24" rod fits into the center post bolt slot.
- At the newly created double sided splice join now connect the 4 guardrail panels to the post using a post bolt. Make sure that before this is done that a 3 1/2" washer is positioned between the post and the guardrail panel on either side.
- Lastly remove the 24" steel rod from the completed section and set aside for use with the next guardrail panels. At this center post bolt slot, connect the panels together to the post with the same bolt and washer assembly as outlined in the previous step.

Nu-Guard-31™ Roadside Option

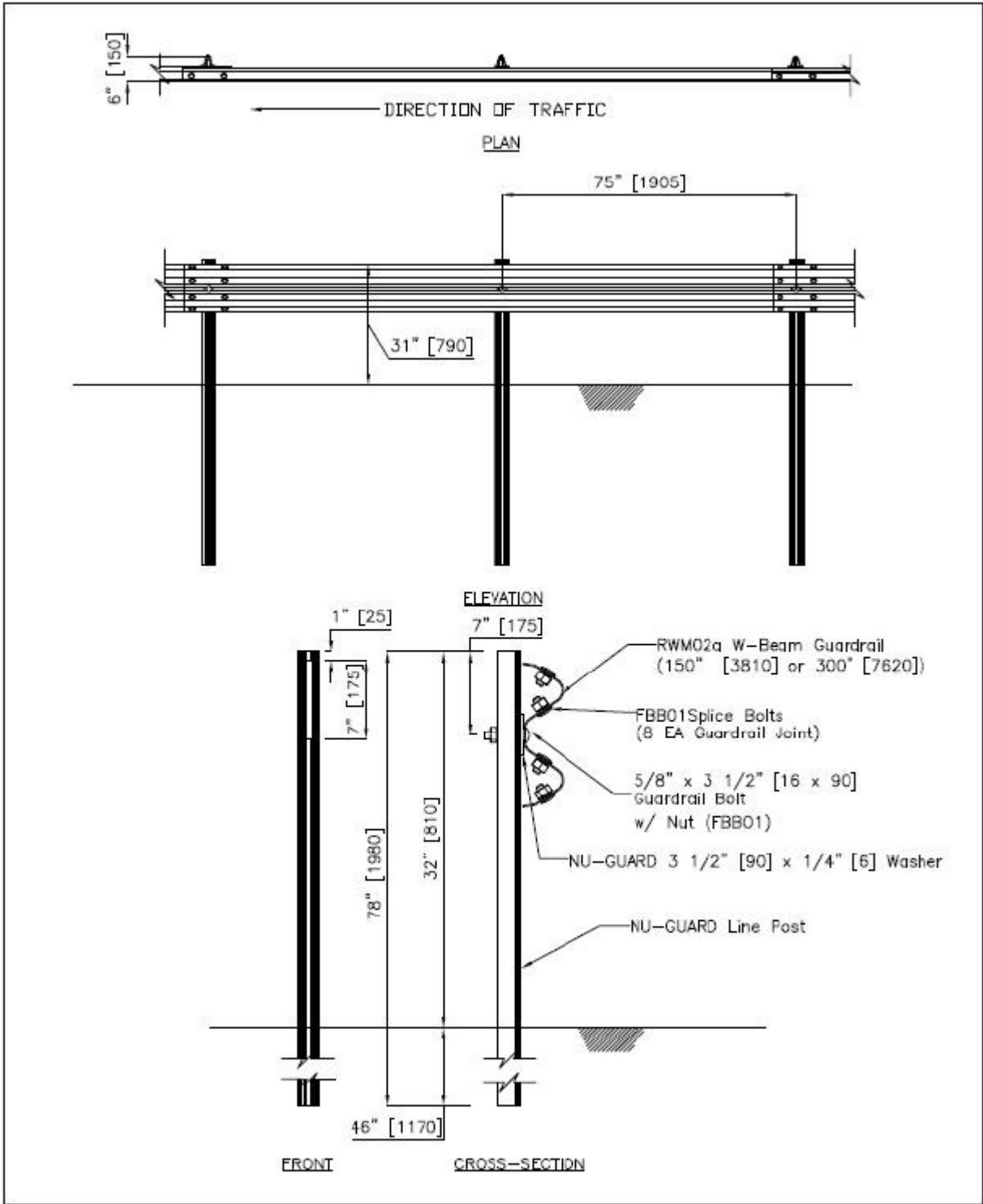

NU-GUARD-31 ROADSIDE BARRIER

SGR33

SHEET NO.	DATE:
1 of 2	09/01/2011

INTENDED USE

The NU-GUARD-31 system is a corrugated metal w-beam barrier for use on national, state and local roadways to prevent collisions with hazards as required by safety design standards. The system is designed for roadside applications as an alternate to SGR04, and equivalent to other 31" [790] mounting height w-beam barriers (such as SGR20), for strong or weak post applications. The system may be connected to any crashworthy 31" [790] mounting height guardrail terminal or transition system. The system is to be installed on approach slopes no greater than 10H:1V, wherever a maximum working deflection of 41" [1050] is required for TL-3 applications, and 48" [1220] for TL-4 applications.

COMPONENTS

The posts are Rib-Bak U-Channel sign posts 5 lb/ft [7.4 kg/m] fabricated from hot rolled carbon steel bars conforming to the requirements of NUCOR/Marion Steel Company Grade SP-80 with a minimum yield point of 80,000 psi [552 Mpa]

Unit length = 150" [3810]

Designator	Component	Number
RWM02a	W-beam rail	1
	NU-GUARD Line Post	2
	NU-GUARD 3 1/2" [90] x 1/4" [6] Washer	2
	3 1/2" [90] Guardrail-post bolt and nut	2
FBB01	Splice bolt and nut	8

The system meets NCHRP-350 TL-4 and MASH-08 TL-3 requirements as a longitudinal barrier.

AGENCY ACCEPTANCE

FHWA Acceptance Letter [B-162](#), 09/11/2007

CONTACT INFORMATION

Nucor Steel Marion Inc.
912 Cheney Avenue
Marion, Ohio 43301-1801
(800) 333-4011
(740) 383-6429 Fax
www.nucorhighway.com

NU-GUARD-31 ROADSIDE BARRIER

SGR33		NUCOR BAR MILL GROUP NUCOR STEEL MARION, INC. <i>All Nucor Steel Marion Inc. products are produced from 100% recycled steel.</i>
SHEET NO.	DATE	
2 of 2	09/01/2011	