



POSEYVILLE ROAD CORRIDOR SAFETY IMPROVEMENTS

Ingersoll Township, Midland County

Midland County Road Commission
2334 North Meridian Road
Sanford, Michigan 48657

www.midlandroads.com
facebook.com/MidlandRoads
twitter.com/MidlandCRC

Information Contact
Russell Inman, Design Engineer
e russ@midlandroads.com
p (989) 687-9060

Project Limits:
Gordonville Rd to Brooks Rd (2 miles)

Construction timeline:
April 15, 2019 – August 2019

Total Estimated Project Cost:
\$1,248,300.00

Total HRRR Safety Program Grant:
\$600,000.00

Location Map

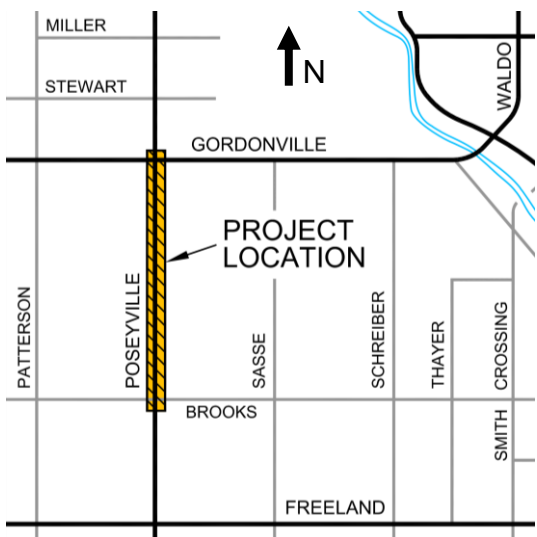

2019 CONSTRUCTION PROJECT INFORMATION

In August 2015, Midland County Road Commission (MCRC) and Michigan Department of Transportation (MDOT) personnel conducted a Local Safety Initiative Review of roadway corridors and intersections within Midland County. The review identified the top 10 corridors and intersections where vehicle crashes are occurring.

The Poseyville Road corridor was highlighted in the review as having a high crash history with multiple fatalities. MCRC personnel applied for and received a \$600,000 High Risk Rural Road (HRRR) Safety Program Grant to improve safety and reduce crashes along this corridor. There are a very high number of fixed-object crashes due to people running off the roadway. Safety will be improved by reducing the number of fixed-objects, such as trees and culvert ends. Most of the trees within the 66' road right-of-way (ROW) will be removed. Road shoulders will be widened to 4' paved and 2' gravel. The relocation and enclosure of existing drainage will provide shallower slopes for vehicles that do depart from the travel lane. Lastly, the roadway will also be resurfaced providing a safer corridor for cars, bikes, and walkers.

The project will reduce crashes by providing the following:

- Reducing fixed-objects
- Drainage enclosure
- Slope flattening
- Widening shoulders to 6' (4' paved + 2' gravel)
- New asphalt road surface

PROPOSED TYPICAL CROSS SECTION

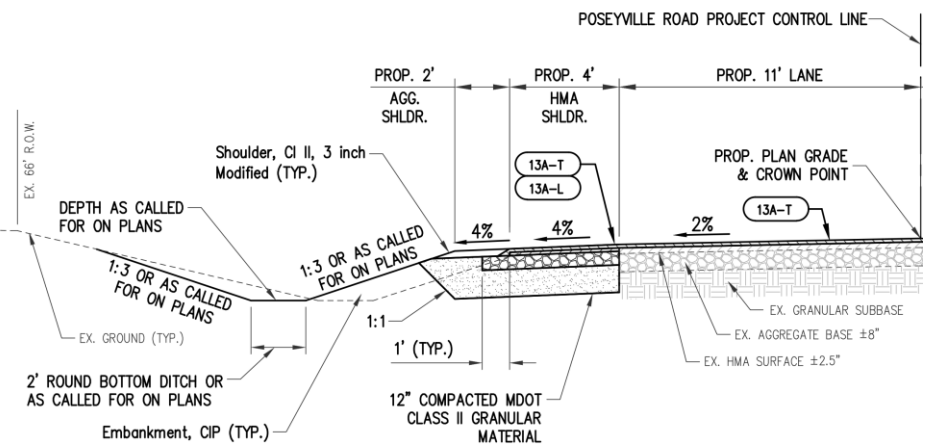

Project plans are available for review at Ingersoll Township and at the Midland County Road Commission office in Sanford, MI.